

nexusTM310

Filtration System

Installation and instruction manual



IMPORTANT PLEASE READ BEFORE CONTINUING WITH INSTALLATION

This manual will give you all the information needed to both install and operate your Nexus 310. First step is to establish which of the two methods of installation you intend to use. The Nexus 310 you have bought comes complete with all it requires to connect up in either of the following configurations:-

ARE YOU PUMP FED? By this we mean that if your pump is going to be used to supply the water to the filter, and the filtered water then returns back into your pond via gravity, i.e. down a waterfall, or through a large diameter pipe, this is referred to as **PUMP FED** (i.e. the water is fed to the filter using a pump).

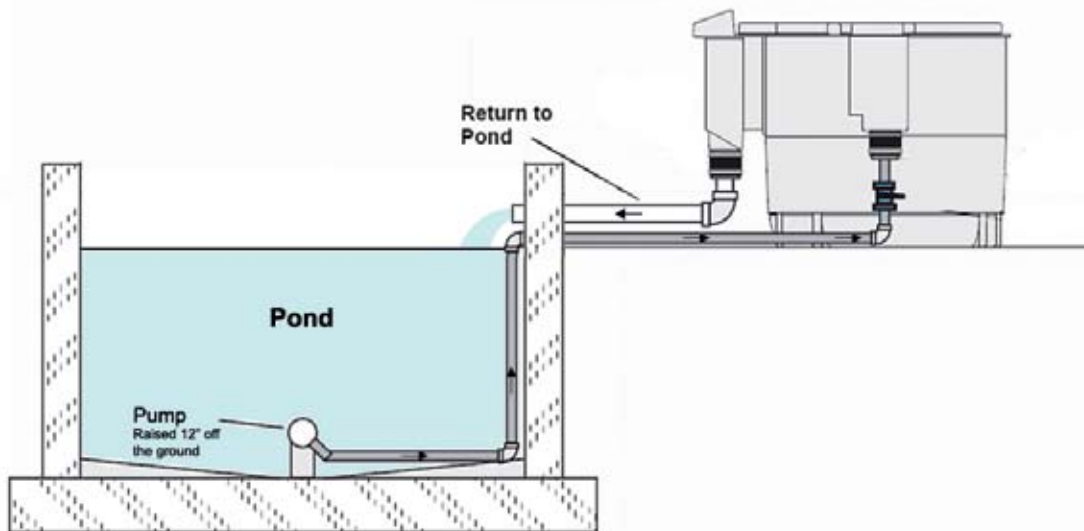

ARE YOU GRAVITY FED? By this we mean that your pump is going to be used to return the filtered water to the pond and therefore your filter will be supplied by gravity via a larger diameter pipe. In this situation the water level in the filter will be at the same level as the pond.

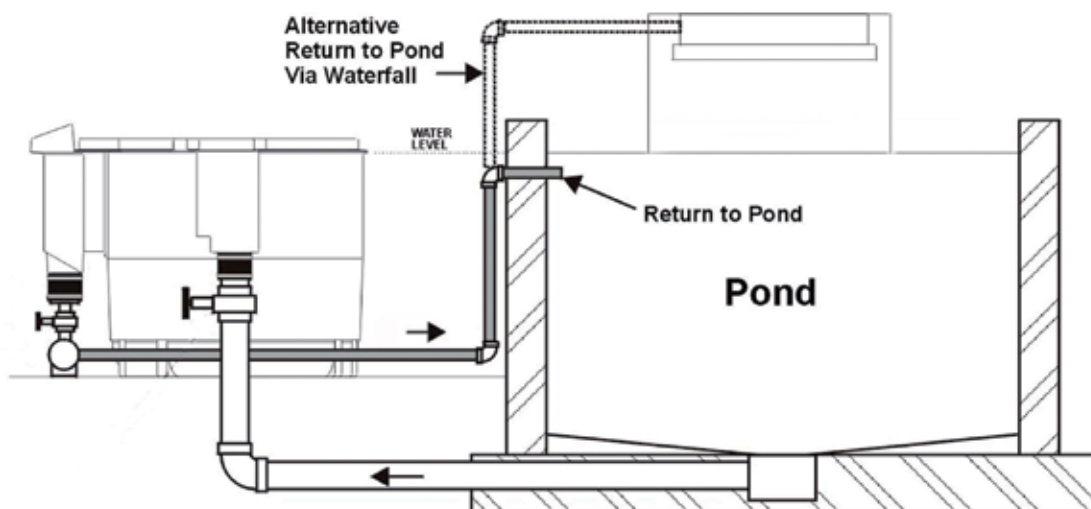

ENSURE THAT ONCE YOU HAVE ESTABLISHED WHICH SET UP YOU WANT TO USE, REFER ONLY TO THE CORRECT SECTION IN THIS MANUAL.

TABLE OF CONTENTS

	Page
Table of contents	2
How your nexus filter works	3
Nexus 310 pump fed installation and operation	4
Nexus 310 gravity fed installation and operation	9
Kaldnes moving bed	14
How to get the best from your Nexus filter	15

Your Nexus comes complete with the following items:-



Inlet slide plate



Hose tail inlet assembly
(for use in pump fed setup only)



2 x 50ltr bags of Kaldnes
K1 media to be placed
in outer chamber of the
Nexus 310



K1 media comes already in
place in the Eazy section of
your Nexus 310. The precise
amount needed is at the
level indicated in this picture



Bypass collar used in
gravity setup only

HOW IT WORKS

OPERATING YOUR NEXUS:

The Nexus filter is simple yet innovative. Water enters the Nexus via inlet (A) into the inner chamber (B) which works as a basic vortex allowing larger solids to settle out. The water then passes through the Eazy (C) where the finer particles are removed and the first step in biological treatment takes place. From the Eazy the water passes into the outer chamber (D) where the remainder of the biological treatment takes place using the Kaldnes Moving Bed Process (for further information see page 14 on Kaldnes moving bed)

The water then passes through the grill into the Exit Chamber (E), where it is returned to the pond through the outlet (F). Waste is discharged through the larger Ball valve (G). The Eazy is cleaned by diverting the air from the Outside chamber to the Eazy using the air valves (H).

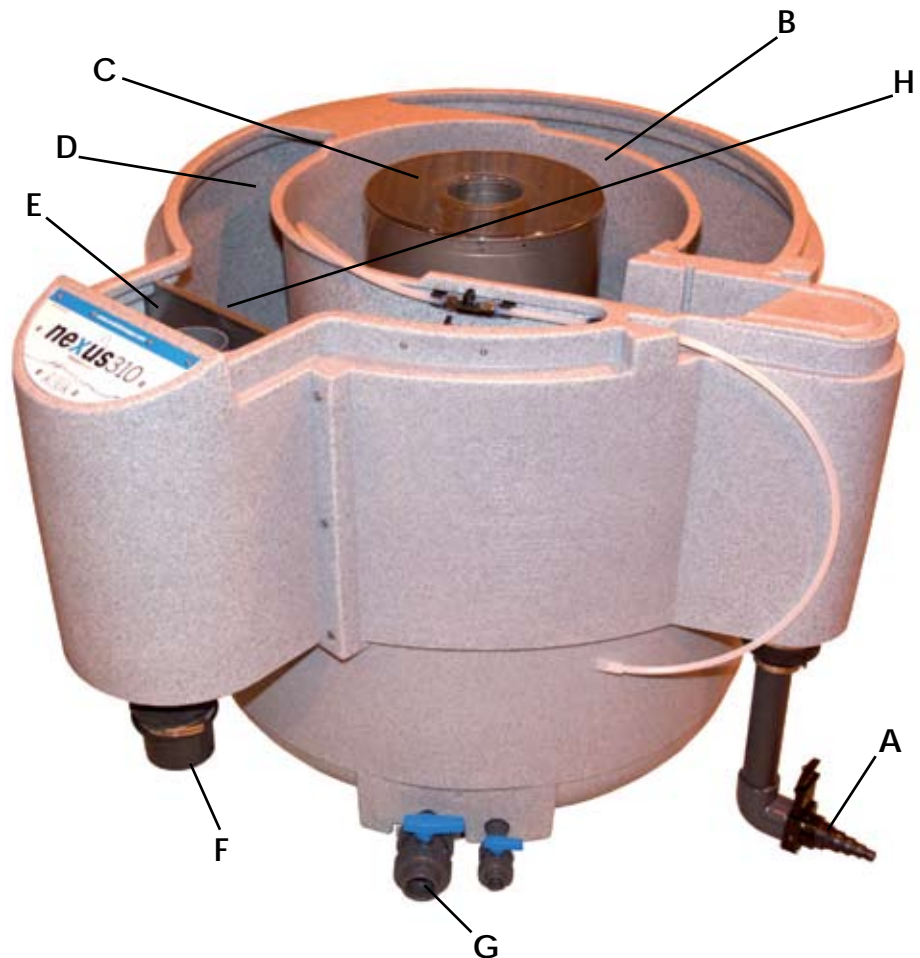

EAZY :

The Eazy is a stainless steel vessel containing a set volume of static K1 media (40L for Nexus 310) which is located within the centre chamber of the Nexus. After water enters the Nexus it rotates around the Eazy in the centre chamber with a downward motion allowing the larger

solids to settle to the bottom of the chamber before passing through the slots of the Eazy into the static K1 media. The water flows upwards through the K1 media where mechanical filtration takes place as any small particles are caught within the K1 media. The water then flows through the slots in the centre column and into the outer chamber.

OUTER CHAMBER:

The outer chamber of the Nexus contains the Kaldnes Moving Bed Process. This is where the final stage of biological treatment occurs. Biological breakdown occurs through different strains of bacteria living on the K1 media. These bacteria convert Ammonia and Nitrite into harmless Nitrate. The amount of Ammonia and Nitrite produced in the pond is dependant on feed rates and the type of food. For higher feed rates additional K1 media should be added into the outer chamber (250g/day of average protein content food will be broken down by 50L of K1).

nexusTM310

Filtration System

Pump fed installation and operation
manual



NEXUS 310 PUMP FED INSTALLATION

IMPORTANT PREPARATION

A solid and level base is required. It should be a minimum of 1.2m x 1.0m, to allow easy access to valves and for maintenance purposes. The Nexus filter needs to be well supported, this is to prevent possible distortion when it is full of water. The best option for this would be a level 100 mm thick concrete plinth, although decking or paving slabs would be sufficient as long as the Nexus sits level and is not allowed to deflect under the weight of the water.

Check all the jubilee clips on the 3eazyconnectors are tight to prevent leaks.

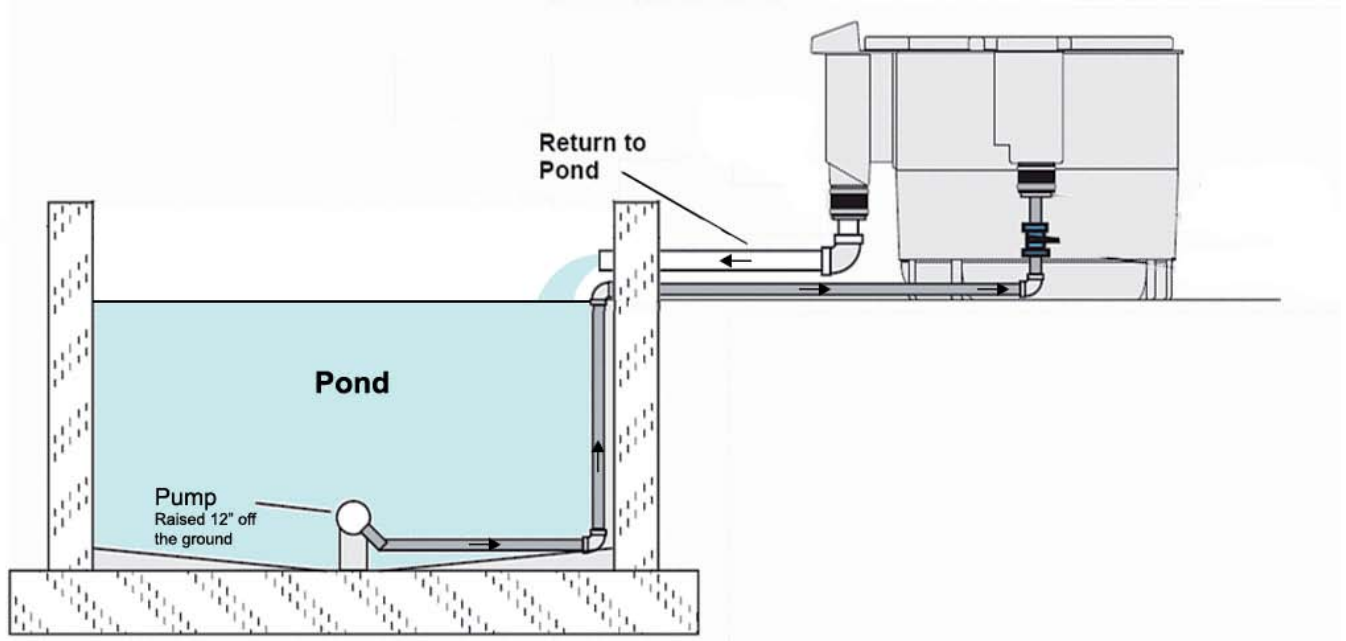

specification	nexus eazy 310
Max Flow Rate	13,000 litres/hr 2,859 UK gallons/hr 3,431 US gallons/hr
Kaldnes Media	100 ltrs bio/40 ltrs Eazy
Max Capacity	300 ltrs bio/40 ltrs Eazy
Max Pondsized	34,000 litres 7,500 UK gallons 9,000 US gallons
Rec. Airpump	Airpump 95+
Volume of water in filter	185 UK gallons 840 litres 222 US gallons

Table 1

Total Biological Media litres	Recommended Airpump
50-75	Airpump 75
75-100	Airpump 95
100-150	Airpump 130
150-300	Airpump 150

NEXUS 310 PUMP FED INSTALLATION

INSTALLATION EQUIPMENT REQUIRED

1. Pond Pump, with an actual flow rate that delivers to the filter a maximum of 13,000 Ltrs/hour or the entire volume of water in the pond, every two hours, whichever is the greater.
2. Air Pump. See table 1 on page 5.
3. A valve should be fitted before and after the Nexus so that the Nexus can be isolated if required.
4. It is highly recommended that a suitably sized UV unit is installed with the Nexus for removal of single celled algae. UV systems are always installed after the pump.

NEXUS 310 PUMP FED INSTALLATION

Your Nexus 310 has been supplied to you ready for you to set up for Pump fed operation.

Pump Fed Installation Steps:

1. Attach the Hosetail assembly (fig 1) to the Nexus Inlet (A)
2. Connect the hose/pipework from your pump to the hosetail, cutting down the Hose tail to fit the correct hose, we recommend using 1 1/2".
3. Connect your 4" pipework from the Exit pipe (F) back to the Pond.
4. Pour the 2 x 50L K1 media bags into the outside chamber of the Nexus
5. Connect your air pump to the Nexus air inlet (H)
6. Connect the waste valves (G) to your waste outlet as described.

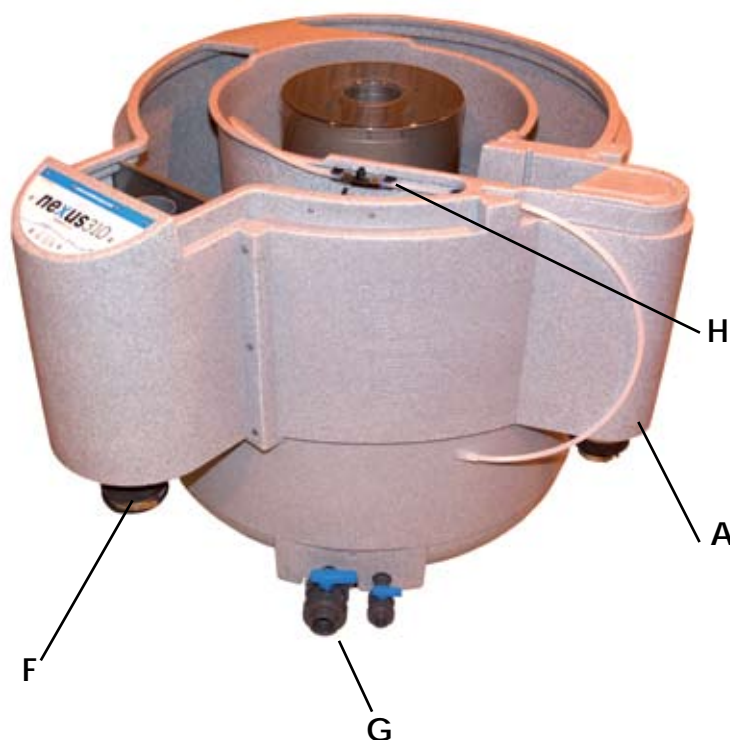

Fig 1



How to remove the clear lid from the Eazy. This is a tight fit. Do not remove the screws

NEXUS310 PUMP FED INSTALLATION

WASTE PIPE CONNECTION

The waste valves are where the waste from your Nexus is discharged when cleaning and prior to draining. The 1 1/2" valve is for the Inner Chamber and is used for when cleaning the Eazy, while the 3/4" valve is for draining the outer chamber (only when and if required).

Both of these valves can be connected using a waste pipe kit (optional extra) as shown in Figs 2.1-2.3 or can just be discharged individually. If the Nexus is located below your drain height the waste can be either discharged into a sump where a submersible pump can be used to pump the waste away or an in-line pump can be connected to the waste line where it can pump directly to waste.

Once your Nexus is installed and plumbed in as described above, you are ready to fill the Nexus and begin treating your pond water.



Fig 2.1 Installed

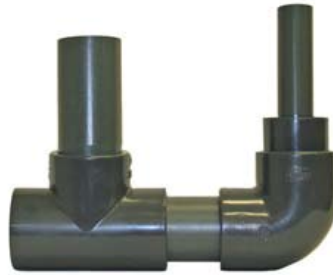

Fig 2.2 Exit to left



Fig 2.3 Exit to right

OPERATING YOUR NEXUS 310 PUMP FED

Once your Nexus is installed and plumbed in as instructed, you are ready to fill the Nexus and begin filtering your pond water.

To fill your Nexus first you need to open the inlet valve. With a pump fed unit you then need to switch on your pump.

Once the Nexus is full, you will notice that the Kaldnes K1 media in the outer chamber, will float on the surface of the water. In a pond containing fish, the media will begin moving completely within a week. This is perfectly normal.

Now your Nexus is full it is time to turn on your air pump to circulate the media making sure the air valve to the outer chamber is open and the valve to the Eazy is closed.

NEXUS310 PUMP FED INSTALLATION



Fig 3.1 Normal operation



Fig 3.2 Needs cleaning

CLEANING YOUR NEXUS 310 PUMP FED

The central 'Eazy' section of the Nexus will collect all the debris and suspended solids that come into the filter. In time you will find out how often you need to clean this, and probably get into a routine to keep the filter working at its optimum. Each pond is different, and the regularity of cleaning is affected by stocking levels and feeding rates along with other factors such as algae in the pond.

WHEN TO CLEAN?. The indication that your filter requires cleaning is when you see water flowing out of the overflow as in Fig 3.2. Normally we would not recommend leaving the filter uncleaned more than 3 weeks. The filter can be left longer if absolutely necessary but this would not be best practice.



Fig 3.3

Cleaning procedure

1. Close the valve at the Nexus inlet and immediately switch off your pump.
2. Close the inlet to the inner chamber by inserting inlet slide-plate supplied with your Nexus. Your Eazy is now isolated from the rest of the system
3. Turn the air valve (H) to divert the air into the Eazy, close the air valve (H) to the bio stage.
4. The K1 media in the Eazy will now be agitated vigorously, or 'boil'. As this happens, all the debris trapped in the K1 will be released into the vortex area of the central chamber.
5. After about 5 minutes, open the waste valve (G), allowing the waste to drain out with the water Fig 3.3.
6. Take out the inlet slide plate.
7. Open the valve on the inlet, switch on your circulating pump.
8. Close the waste valve (G).
9. Close the air valve (H), to the inner chamber and open the air valve (H) to the outer chamber.
10. We would recommend that you perform the cleaning process twice wherever possible to ensure best results.

nexusTM310

Filtration System

Gravity fed installation and operation
manual



NEXUS310 GRAVITY FED INSTALLATION

NEXUS 310 GRAVITY FED INSTALLATION

A gravity fed system is where the water level in the Nexus is at the same height as the water level in the pond, therefore it is critical that the Nexus is installed so that the lip at the top of the Nexus should be level with the proposed finished surface water level of the pond. The plinth for your Nexus, should be 950mm below where you want the finished pond water surface to be. Please see diagrams below.

The water on a Gravity fed system should be fed from an appropriately placed bottom drain through at least a 4 inch (110mm) pipe with as short a length and fewer bends as possible (For optimum flow swept bends should be used). At the end of the bottom drain line before entering the Nexus, a valve is required so that the line can be shut and the Nexus isolated.

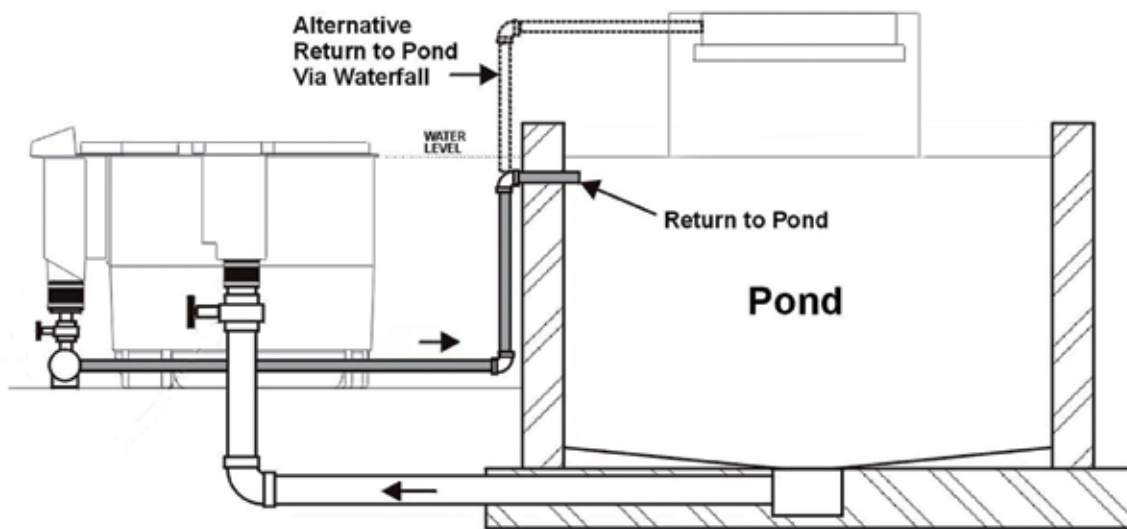

For long bottom drain pipe runs, it is recommended that a 'T' purge valve line is installed to remove solids that may settle in the bottom drain line. This should discharge straight to waste (if possible) or into a suitably sized sump.

It is very important that when laying the bottom drain line that there is no section where the pipework rises then falls as airlocks can form in this area which will block flow. Figure 1 below describes what should and shouldn't be done.

Pipework should be level until reaching the filterhouse where it should ideally go through a swept bend 90 into the Nexus inlet.

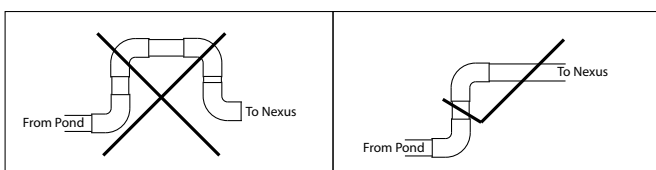
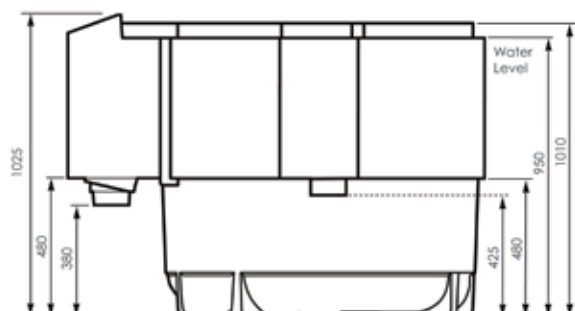
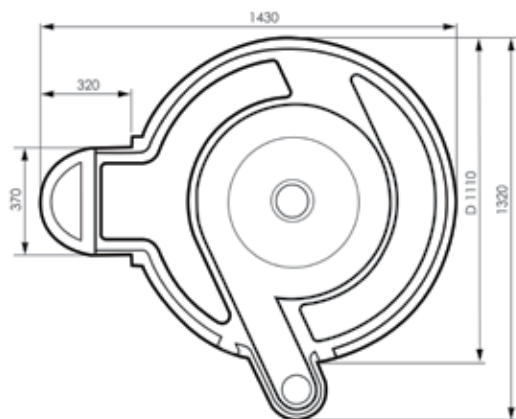

Fig 1



NEXUS 310 GRAVITY FED INSTALLATION

NEXUS 310 GRAVITY FED INSTALLATION

Your Nexus 310 comes with a stand pipe in the outlet. This is for use in **PUMP FED SET UPS ONLY**. Please remove the standpipe from the Nexus outlet by undoing the jubilee clip (Fig 2.1) and removing the 4"- 4" eazyconnector (Fig 2.2), remove the 3 retaining screws (Fig 2.3) and slide out the 4" PVC pipe (Fig 2.4).



Fig 2.1



Fig 2.2



Fig 2.3



Fig 2.4

Your nexus 310 is now ready to be connected up for gravity fed operation.

Setup procedure



Fig 3.1



Fig 3.2



Fig 3.3



Fig 3.4

1. Remove the 4"- 2" eazyconnector from Nexus inlet (A) (Fig 3.1).
2. Attach the 4"-2" eazyconnector (Fig 3.3) to the Nexus Outlet (F) (Fig 3.2).
3. Attach the 4"-4" eazyconnector to the Nexus Inlet (A) (Fig 3.4) and then to the 4" pipe work from your pond.
4. Connect your water pump to the 4"-2" eazyconnector using suitable pipe work. A valve should be positioned between the pump and the Nexus, to isolate the Nexus during cleaning.
5. Pour the 2 x 50L K1 media into the outside chamber (D) of the Nexus (Fig 5).
6. Fit the bypass collar provided into position. See fig 4.1 to 4.3.
7. Connect your air pump to the Nexus air valves (H).
8. Connect your pump outlet to the remainder of your pipework including a UV steriliser.
9. Connect the waste valves (G) to your waste outlet



Fig 4.1

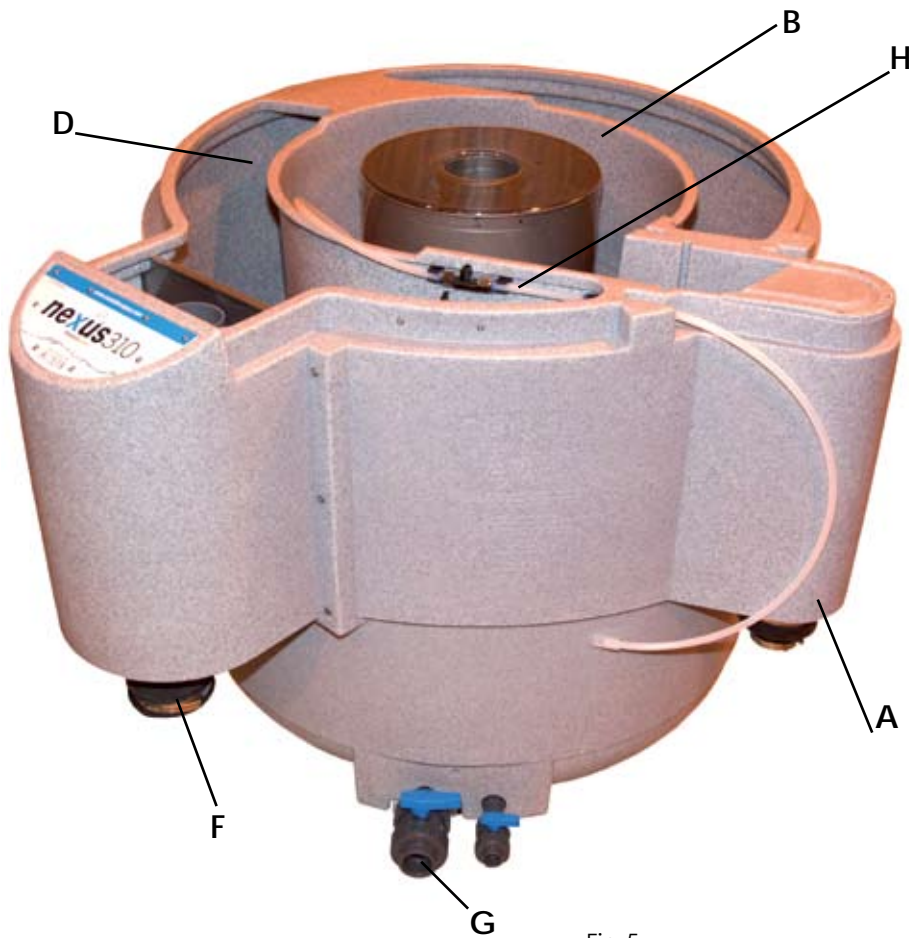

Fig 4.2



Fig 4.3

NEXUS 310 GRAVITY FED INSTALLATION



How to remove the clear lid from the Eazy. This is a tight fit. Do not remove the screws

Fig 5

WASTE PIPE CONNECTION

The waste valves are where the waste from your Nexus is discharged when cleaning and prior to draining. The 1 1/2" valve is for the Inner Chamber (B) and is used for when cleaning the Eazy, while the 3/4" valve is for draining the outer chamber (D) (only when and if required).

Both of these valves can be connected using a waste pipe kit (optional extra) as shown in Figs 6.1-3 or can just be discharged individually. If the Nexus is located below your drain height the waste can be either discharged into a sump where a submersible pump can be used to pump the waste away or an in-line pump can be connected to the wasteline where it can pump directly to waste.

Once your Nexus is installed and plumbed in as described above, you are ready to fill the Nexus and begin treating your pond water.



Fig 6.1 Installed



Fig 6.2 Exit to right



Fig 6.3 Exit to left

NEXUS 310 GRAVITY FED INSTALLATION

OPERATING YOUR NEXUS 310 GRAVITY FED

Once your Nexus is installed and plumbed in as instructed, you are ready to fill the Nexus and begin filtering your pond water.

To fill your Nexus first you need to open all the valves before and after the Nexus.

The system should be filled until the water levels are equal.

Once the Nexus is full, you will notice that the Kaldnes K1 media in the outer chamber, will float on the surface of the water. In a pond containing fish the media will begin moving completely within a week, this is perfectly normal.

Now your Nexus is full it is time to turn on your air pump to circulate the media making sure the air valve to the outer chamber is open and the air valve to the Eazy is closed.

CLEANING YOUR NEXUS 310 GRAVITY FED

The central 'Eazy' section of the Nexus will collect all the debris and suspended solids that come into the filter. In time you will find out how often you need to clean this, and probably get into a routine to keep the filter working at its optimum. Each pond is different, and the regularity of cleaning is affected by stocking levels and feeding rates along with other factors such as algae in the pond.

WHEN TO CLEAN? You may also notice that the water level in the outer chamber – the Biological stage – lowers as water is prevented from getting through the Eazy as quickly as it is being pumped back into the pond. When this water level falls beneath the level of the bypass pipe, this is the indication that you should clean the Eazy. Normally we would not recommend leaving the filter uncleaned more than 3 weeks. The filter can be left longer if absolutely necessary but this would not be best practice.

Cleaning procedure

1. Switch off your circulation pump.
2. Close the inlet to the Nexus by inserting inlet slide-plate supplied with your Nexus. Your Eazy is now isolated from the rest of the system
3. Turn the air valve to divert the air into the Eazy, close the air valve to the bio stage.
4. The K1 media in the Eazy will now be agitated vigorously, or 'boil'. As this happens, all the debris trapped in the K1 will be released into the vortex area of the central chamber.
5. After about 5 minutes, open the waste valve (G), allowing the waste to drain out with the water.
6. Close the waste valve (G).
7. Take out the slide plate
8. We would recommend that you perform the cleaning process twice wherever possible to ensure best results.
9. Close the air valve, to the inner chamber and open the air valve to the outer chamber.
10. Switch on your circulation pump.

LONGER PERIOD OF TIME BETWEEN CLEANING

Regular cleaning of the Eazy is essential to maintain your pond at its best. Build up of detritus in any pond filter can harbour pathogens, and other pollutants which may harm your fish.

At times, you may want to leave your filter for longer than you would normally want between cleaning, perhaps if you go on holiday. In these instances, your Nexus 310 incorporates a Bypass, which will prevent the bio stage from emptying, and therefore potentially starving your pump of water, should your Eazy become full of debris. The filter bypass should be turned 90 degree as per figs. 7.1-7.3, when you need to leave your filter for longer periods of time such as holidays etc. this will allow the water to bypass the eazy should it be-

NEXUS 310 GRAVITY FED INSTALLATION

come blocked. On return from your holidays - turn the bypass back to 12.00 o'clock see Fig 7.1. Normally we would not recommend leaving the filter uncleaned more than 3 weeks. The filter can be left longer if absolutely necessary but this would not be best practice.



Fig 7.1



Fig 7.2



Fig 7.3

KALDNES MOVING BED

KALDNES MOVING BED

The Kaldnes Moving Bed™ process, has been scientifically tried and tested in fish farming and waste treatment for over 10 years. Developed by Professor Halvard Ødergard at Trondheim University of Science and Technology the Kaldnes Moving Bed™ bio film process has been designed



AnoxKaldnes

specifically to create the most effective environment for the nitrification process to take place. The media is engineered in a wheel shape and is slightly positively buoyant, allowing a small amount of water flow created by adding air to the process) to circulate the media throughout the vessel.

Oxygen and food (ammonia and nitrite) gives the bacteria the means to grow, whilst the Kaldnes media provides maximum surface area for the bacteria to colonise and produce bio film. It is this process, which removes harmful ammonia and nitrite from the water. As the Kaldnes media chaotically circulates within the bio tank, it causes old dead bacteria/bio film on the outside, to be removed making space for new younger heavier feeding bacteria/bio film to colonise.

Within the wheel, is a protected surface, which enables colonies of bacteria to naturally follow their life cycle, maturing and dying, in turn fuelling the latter stages of nitrification conversion process. It also assists in the breakdown of any small particles passing through from the mechanical stage. Therefore, the Kaldnes media maintains both a young bio-film & a maturing bio film providing a more consistent filter performance, whilst improving water quality, encouraging healthier Koi and aiding in reducing green water and blanket weed. Due to chaotic movement of Kaldnes K1 media, the process is self-cleaning and requires no maintenance. This allows the filter to reach optimum effectiveness without the disturbance of periodic maintenance, avoiding unnecessary loss of bacteria within the filter preventing high levels of ammonia and nitrite within the water. The other major benefit of Kaldnes K1 media is the huge 'active' surface area available for the bacteria to grow on compared to other types of media. This feature allows for smaller filter design, e.g. the Nexus, whilst providing increased biological efficiency.

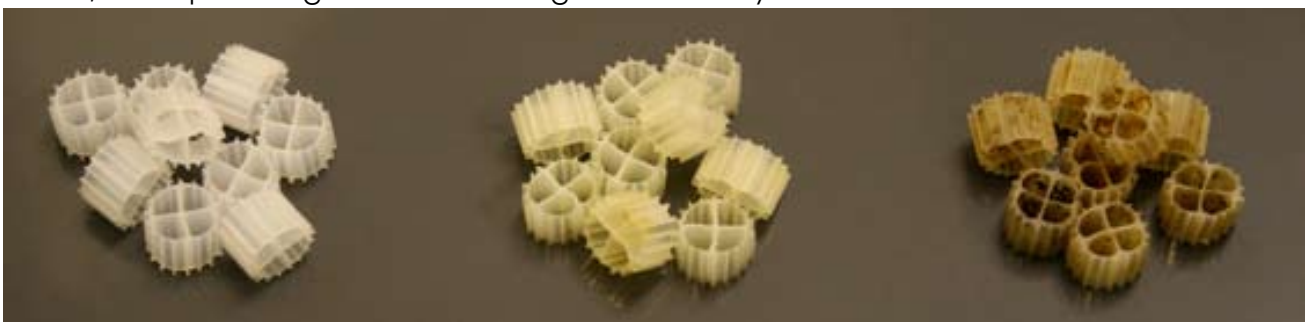

New media

Low loading mature

Heavy loading mature

HOW TO GET THE BEST FROM YOUR NEXUS FILTER

HOW TO GET THE BEST FROM YOUR NEXUS FILTER

Take a look of our new Pure Pond bacteria gel balls.

With over 8,000,000,000 bacteria per Litre of Pure Pond Balls, your pond will shine, especially if you add them monthly into the Kaldnes Moving bed.

The Pure Pond balls are made from a biodegradable polymer, and crammed full of bacteria that are slowly released when they are needed most.

When you introduce the Pure Pond balls into the biological chamber of your Nexus, they become one with moving bed, agitating alongside the K1 media, just waiting to smooth out the peaks and troughs of the Ammonia/Nitrite cycle.

Contact your Nexus dealer to find out more.

Getting the most from your Nexus has never been easier.

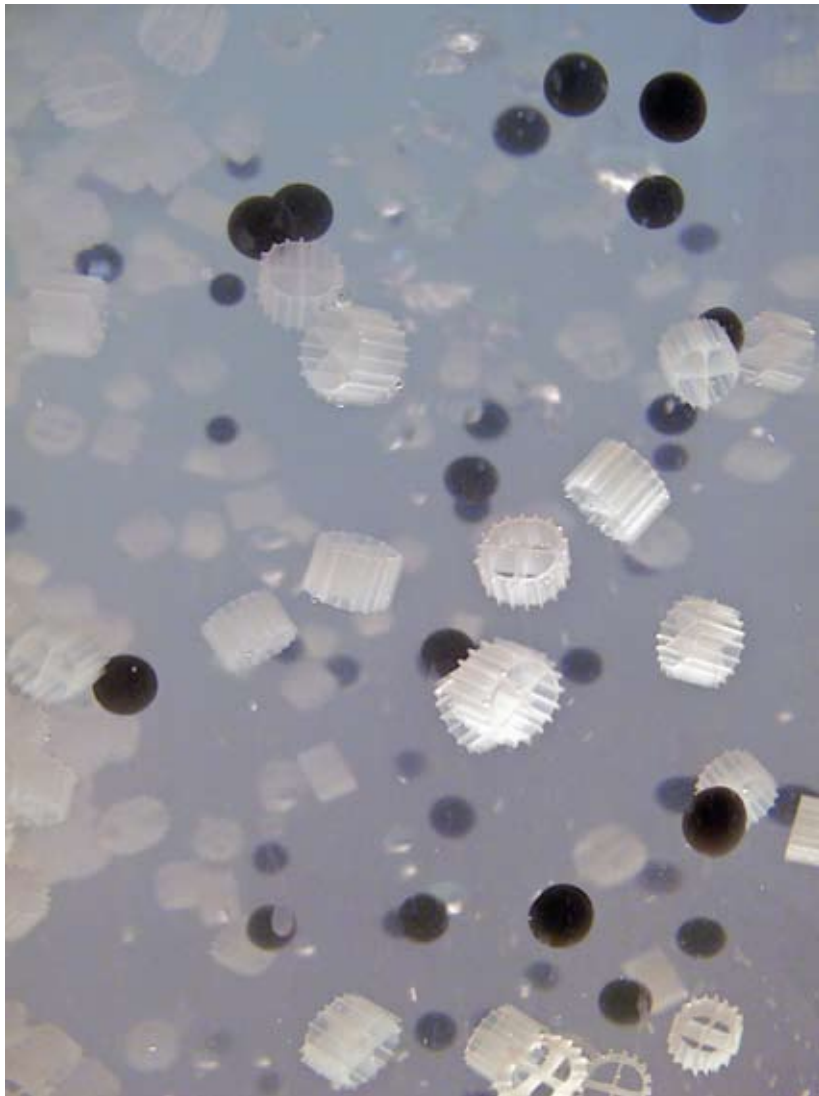

Pure Pond bacteria gel balls in the Kaldnes moving bed filter.